

# NEXUS 100 ZIP GUÍA ESTRECHA

*NEXUS 100 ZIP THIN GUIDE*

*NEXUS 100 ZIP GUIDE ÉTROIT*

*NEXUS 100 ZIP GUIDA STRETTA*



**gaviota**  
The Sun & Shutter Specialists



**E** **Manual de Instalación**

**F** *Manuel d'Installation*

**GB** *Assembly Instructions*

**I** *Manuale di Installazione*



# NEXUS 100 ZIP GUÍA ESTRECHA

NEXUS 100 ZIP THIN GUIDE • NEXUS 100 ZIP GUIDE ÉTROIT • NEXUS 100 ZIP GUIDA STRETTA



**E** Advertencias de seguridad

**GB** Safety warnings

**F** Avertissement de sécurité

**I** Avvertence e note di sicurezza

- E** • Leer detenidamente estas instrucciones de montaje antes de cualquier uso y conservarlas después de la instalación..
- E** • El no respetar las instrucciones de montaje, uso y especificaciones técnicas del artículo, así como excederse en los rangos de uso máximos especificados (pesos, etc...), significará la exclusión de la Política de Garantía y de Servicio Postventa de Gaviota Simbac, S.L.
- GB** • Read carefully the assembly instructions before installing the awning.
- GB** • Failure to follow the assembly instructions, use conditions and technical specifications of the article, as well as exceeding the specified maximum use ranges (weights, etc ...), will mean the exclusion of the Warranty and After Sales Service Policy of Gaviota Simbac, S.L.
- F** • Lire attentivement les instructions de montage avant de procéder à l'installation du store.
- F** • *maximus spécifiés (poids, etc...), sera motif d'exclusion de la Politique de Garantió et Service Après-vente de Gaviota Simbac, S.L. Leggere queste istruzioni prima dell'uso e conservarle l'installazione.*
- I** • Leggere attentamente le istruzioni di montaggio prima di montare la tenda da sole.
- I** • La mancata osservanza delle istruzioni per il montaggio, l'uso, le specifiche tecniche di questo articolo, e degli intervalli che superano il massimo utilizzo specificato (pesi, ecc ...), significherà l'esclusione della Politica della Garanzia e Servizio Post-Vendita GAVIOTA SIMBAC, S.L.

## Índice • Index • Index • Indice

- 01** Listado de componentes • Hardware list  
*Liste de composants • Elenco dei componenti*
- 02** Explosionados • Exploded view  
*Exposition pièces • Grafico esplosivo*
- 03** Rango de uso. Descuentos • Range of use. Cutting table  
*Gamme d'utilisation. Remises • Intervallo d'uso. Dimensioni*
- 04** Preparación de componentes • Hardware preparation  
*Préparation de composants • Preparazione dei componenti*
- 05** Montaje en fábrica • Factory assembly  
*Montage en usine • Montaggio in fabbrica*
- 06** Montaje en obra • On-site assembly  
*Montage sur site • Montaggio in opera*



# NEXUS 100 ZIP GUÍA ESTRECHA

NEXUS 100 ZIP THIN GUIDE • NEXUS 100 ZIP GUIDE ÉTROIT • NEXUS 100 ZIP GUIDA STRETTA

01

Listado de componentes • Hardware list

Liste de composants • Elenco dei componenti

Nº	Código Code	Artículo • Article
1a	80170891	Juego Testeros Screen Nexus 100 blanco • Screen Nexus 100 end cap set white
1b	80170897	Juego Testeros Screen Curve Nexus 100 blanco • Screen Nexus Curve 100 end cap set white
2	80170010	Soporte lateral Ø50 Screen Rits • Ø50 Screen Rits lateral support
3a	80170530	Soporte New lateral motor Gaviota Screen Rits • Screen Rits Gaviota motor new lateral support
3b	80170009	Soporte lateral motor Somfy Screen Rits • Somfy motor Screen Rits lateral support
4a	80170147	Casquillo adaptador polea Ø70 Screen Rits • Ø70 Screen Rits pulley adaptor bearing
4a	80170485	Casquillo adaptador polea Ø70 motor Somfy • Ø70 Somfy motor pulley adaptor bearing
4b	80170011	Casquillo adaptador polea Ø78 Screen Rits • Ø78 Screen Rits pulley adaptor bearing
4b	80170486	Casquillo adaptador polea Ø78 motor Somfy • Ø78 Somfy motor pulley adaptor bearing
5	60070059	Corona para eje Ø70 ojiva S45 Gaviota • Ring gear set for Ø70 ogive axis S45 Gaviota
5	60070060	Corona para eje Ø78 ojiva S45 Gaviota • Ring gear set for Ø78 ogive axis S45 Gaviota
6a	80170012	Anillo fijación Screen Rits • Screen Rits fixation ring
6b	80170942	Anillo fijación motor Elite-i Screen Nexu • Elite-i motor Screen Nexus fixation ring
7	80170531	Tapa guía izquierda screen Rits 90° • Screen Rits 90° Left guide cover
8	80170532	Tapa guía derecha screen Rits 90° • Screen Rits 90° Right guide cover
9	80170785	Kit tapa barra de carga izquierda Nexus 80 blanco • Left charge profile cover for Nexus 80 white
10	80170786	Kit tapa barra de carga derecha Nexus 80 blanco • Right charge profile cover for Nexus 80 white
11	80170879	Perfil cajón para Screen Nexus 100 blanco 7m • Box profile for Screen Nexus 100 white 7m
12a	80170882	Perfil registro Screen Nexus 100 blanco 7m • Screen Nexus 100 Upper profile white 7m
12b	80170885	Perfil registro Screen Curve Nexus 100 blanco 7m • Screen Nexus Curve 100 Upper profile white 7m
13	80170851	Perfil cierre lona PVC Screen HD negro 6m • Screen HD PVC canvas closure profile black 6m
14	80170552	Perfil guía anterior Screen Rits 90° blanco 7m • Screen Rits 90° Front guide profile white 7m
15	80170034	Perfil guía posterior Screen Rits 90° blanco 7m • Screen Rits 90° Back guide profile white 7m
16	80170842	Perfil Barra Carga Screen Nexus 80 guía blanco 7m • Screen Nexus 80 Charge profile white 7m
17	80170055	Barra refuerzo Ø22 Screen Rits zincada 4m • Ø22 Screen Rits galvanised reinforcement rod 4m
18	80170054	Felpudo pb-48-800-3pb cortado a 5m Screen • Brush seal pb-48-800-3pb cut at 5m Screen
19a	80030024	Tubo ranurado ojiva Ø70x1 4m • Threaded tube with ogive Ø70x1 4m
19b	80030020	Tubo ranurado ojiva Ø78x1 4m • Threaded tube with ogive Ø78x1 4m
20	60050232	Motor Elite-i 20/15 cabeza 9mm S45 • Elite-i 20/15 motor 9mm head S45
	<b>80170903</b>	<b>Bolsa tornillería Screen Nexus 100 Zip • Screen Nexus 100 Zip hardware bag</b>
21		Tornillo Allen M4x25 DIN-910 inox A4 • Hexagon head screw M4x25 DIN-910 SS A4
22		Tornillo cabeza Alom M4x10 DIN-7985 inox A2 • Pan head screw M4x10 DIN-7985 SS A2
23		Tuerca cuadrada M4 DIN-562 inox A2 • Square nut M4 DIN-562 SS A2
24		Tornillo Ø4,2x50 DIN-7982 DACRO • Screw Ø4.2x50 DIN-7982 DACRO
25		Tornillo Ø3,5x6,5 DIN-7981 inox A2 • Screw Ø3.5x6.5 DIN-7981 SS A2
26		Tornillo Ø3,5x16 DIN-7982 inox A2 • Screw Ø3.5x16 DIN-7982 SS A2
27		Tornillo Ø2,9x9,5 DIN-7981 Inox A2 • Screw Ø2.9x9.5 DIN-7981 SS A2
28		Tornillo rosca chapa 3,5x22 DIN-7982 Dacro • Self-drilling screw 3.5x22 DIN-7982 DACRO
29		Tornillo M6x14 DIN-7991 inox A2 • Screw M6x14 DIN-7991 SS A2
30	80170019	Embudo Screen Rits • Screen Rits funnel

# NEXUS 100 ZIP GUÍA ESTRECHA

NEXUS 100 ZIP THIN GUIDE • NEXUS 100 ZIP GUIDE ÉTROIT • NEXUS 100 ZIP GUIDA STRETTA



N°	Code Codice	Article • Articolo
1a	80170891	<i>Jeu châssis Screen Nexus 100 blanc • Kit di testate Screen Nexus 100 bianco</i>
1b	80170897	<i>Jeu châssis Screen Nexus Curve 100 blanc • Kit di testate Screen Nexus Curve 100 bianco</i>
2	80170010	<i>Support latéral Ø50 Screen Rits • Supporto laterale Ø50 Screen Rits</i>
3a	80170530	<i>Support new latéral moteur Gaviota Screen Rits • Nuovo supporto motore laterale Gaviota Screen Rits</i>
3b	80170009	<i>Support latéral moteur Somfy Screen Rits • Supporto laterale motore Somfy Screen Rits</i>
4a	80170147	<i>Culot adaptateur poulie Ø70 Screen Rits • Boccola adattatore puleggia Ø70 Screen Rits</i>
4a	80170485	<i>Culot adaptateur poulie Ø70 moteur Somfy • Boccola adattatore puleggia Ø70 motore Somfy</i>
4b	80170011	<i>Culot adaptateur poulie Ø78 Screen Rits • Boccola adattatore puleggia Ø78 Screen Rits</i>
4b	80170486	<i>Culot adaptateur poulie Ø78 moteur Somfy • Boccola adattatore puleggia Ø78 motore Somfy</i>
5	60070059	<i>Jeu couronnes pour axe Ø70 ogive S45 Gaviota • Kit di corone per asse Ø70 tenditore S45 Gaviota</i>
5	60070060	<i>Jeu couronnes pour axe Ø78 ogive S45 Gaviota • Kit di corone per asse Ø78 tenditore S45 Gaviota</i>
6a	80170012	<i>Anneau fixation Screen Rits • Anello di fissaggio Screen Rits</i>
6b	80170942	<i>Anneau fixation moteur Elite-i Screen Nexus • Anello di fissaggio motore Elite-i Screen Nexus</i>
7	80170531	<i>Couvercle guide screen Rits 90° • Terminale guida sinistra Screen Rits 90°</i>
8	80170532	<i>Couvercle guide droit screen Rits 90° • Terminale guida destra Screen Rits 90°</i>
9	80170785	<i>Couvercle barre de charge gauche Nexus 80 blanc • Terminale della barra di carico sinistra Nexus 80 bianco</i>
10	80170786	<i>Couvercle barre de charge droite Nexus 80 blanc • Terminale della barra di carico destra Nexus 80 bianco</i>
11	80170879	<i>Profil coffre pour Screen Nexus 100 blanc 7m • Profilo del cassonetto Screen Nexus 100 bianco 7 m</i>
12a	80170882	<i>Profil registre Screen Nexus 100 blanc 7m • Profilo superiore Screen Nexus 100 bianco 7 m</i>
12b	80170885	<i>Profil registre Screen Nexus Curve 100 blanc 7m • Profilo superiore Screen Nexus Curve 100 bianco 7 m</i>
13	80170851	<i>Profil fermeture toile PVC Screen HD noir 6m • Profilo di chiusura del telo PVC Screen HD nero 6 m</i>
14	80170552	<i>Profil guide antérieur Screen Rits 90° blanc 7m • Profilo guida anteriore Screen Rits 90° bianco 7 m</i>
15	80170034	<i>Profil guide postérieur Screen Rits 90° blanc 7m • Profilo guida posteriore Screen Rits 90° bianco 7 m</i>
16	80170842	<i>Profil barre charge Screen Nexus 80 blanc 7m • Profilo della barra di carico Screen Nexus 80 bianco 7 m</i>
17	80170055	<i>Barre renfort Ø22 Screen Rits zinguée 4m • Barra di rinforzo Ø22 Screen Rits zincata 4 m</i>
18	80170054	<i>Tapis pb-48-800-3pb coupé à 5m Screen • Spazzola a listello pb-48-800-3pb tagliata a 5 m Screen</i>
19a	80030024	<i>Tube rainuré ogive Ø70x1 4m • Tubo scanalato tenditore Ø70x1 4 m</i>
19b	80030020	<i>Tube rainuré ogive Ø78x1 4m • Tubo scanalato tenditore Ø78x1 4 m</i>
20	60050232	<i>Moteur Elite-i 20/15 tête 9mm S45 • Motore Elite-i 20/15 testa 9 mm S45</i>
	<b>80170903</b>	<b><i>Sac boulonnerie Screen Nexus 100 Zip • Borsa tornilleria Screen Nexus 100 Zip</i></b>
21		<i>Vis Ø4,2x25 DIN-7982 inox A2 • Vite a brugola M4x25 DIN-910 inox A4</i>
22		<i>Vis tête Alom M4x10 DIN-7985 inox A2 • Vite a testa bombata M4x10 DIN-7985 inox A2</i>
23		<i>Écrou carré M4 DIN-562 inox A2 • Dado quadro M4 DIN-562 inox A2</i>
24		<i>Vis Ø4,2x50 DIN-7982 DACRO • Vite per lamiera 4,2x50 DIN-7982 Dacro</i>
25		<i>Vis Ø3,5x6,5 DIN-7981 inox A2 • Vite Ø3,5x6,5 DIN-7981 inox A2</i>
26		<i>Vis Ø3,5x16 DIN-7982 inox A2 • Vite Ø3,5x16 DIN-7982 inox A2</i>
27		<i>Vis Ø2,9x9,5 DIN-7981 inox A2 • Vite Ø2,9x9,5 DIN-7981 inox A2</i>
28		<i>Vis à tête 3,5x22 DIN-7982 Dacro • Vite per lamiera 3,5x22 DIN-7982 Dacro</i>
29		<i>Vis M6x14 DIN-7991 inox A2 • Vite M6x14 DIN-7991 inox A2</i>
30	80170019	<i>Entonnoir Screen Rits • Incavo Screen Rits</i>



# NEXUS 100 ZIP GUÍA ESTRECHA

NEXUS 100 ZIP THIN GUIDE • NEXUS 100 ZIP GUIDE ÉTROIT • NEXUS 100 ZIP GUIDA STRETTA

02

**Explosionados • Exploded view**  
*Exposition pièces • Grafico esploso*

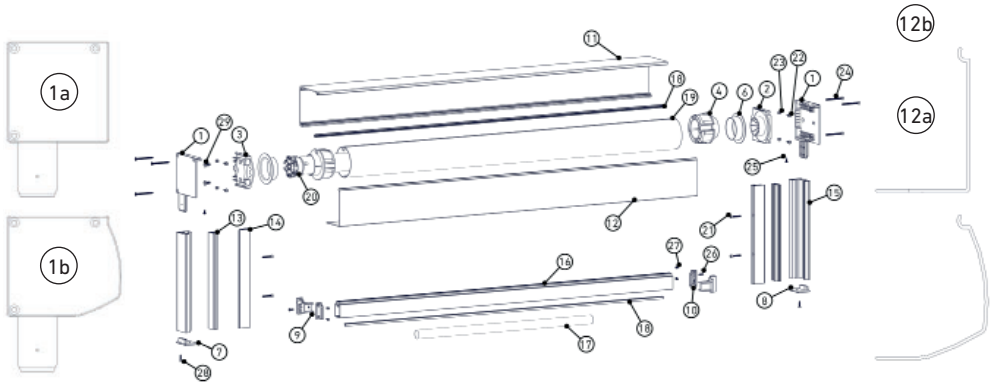

**Despiece eje • Axis exploded view**

*Démontage axe • Vista esplosa dell'asse*

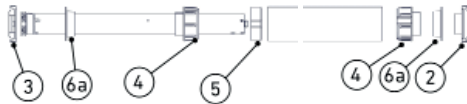

**4-A o 4-B: según el Ø del tubo.**

*4a or 4b: depending on tube Ø.*

*4a ou 4b, selon le Ø du tube.*

*4a o 4b: a seconda del Ø del tubo.*

**En el lado del motor, 3a o 3b: según el tipo de motor.**

*On the side of the motor, 3a or 3b: depending on the motor.*

*Sur le côté du moteur, 3a ou 3b, selon le type de moteur.*

*Sul lato del motore, 3a o 3b: a seconda del tipo di motore.*

# NEXUS 100 ZIP GUÍA ESTRECHA

NEXUS 100 ZIP THIN GUIDE • NEXUS 100 ZIP GUIDE ÉTROIT • NEXUS 100 ZIP GUIDA STRETTA



03

**Rango de uso. Descuentos • Range of use. Cutting table**  
*Gamme d'utilisation. Remises • Intervallo d'uso. Dimensioni*



Rango de uso clase III Range of use: class III Gamme d'utilisation catégorie III Intervallo d'uso classe III		
Tubo • Tube Tube • Tubo	X máxima • maximum maximum • Max.	Y máxima • maximum maximum • Max.
Ø70	4000	3500
Ø78	4000	2700

Tabla descuentos • Cutting table Tableau de remises • Tabella delle dimensioni			
Perfil cajón • Box profile Profil coffre • Profilo del cassonetto	X-30 mm	Perfil barra carga • Charge profile Profil barre charge Profilo della barra di carico	X-86 <sub>(±0,5)</sub> mm
Perfil registro • Upper profile Profil registre • Profilo superiore	X-4 <sub>(+0/-0,5)</sub> mm	Perfil cierre lona PVC con embudo PVC canvas closure profile with funnel Profil fermeture toile PVC avec entonnoir Profilo di chiusura del telo PVC con incavo	Y-114 <sub>(+0/-1)</sub> mm
Perfil guía anterior • Front guide profile Profil guide antérieur Profilo guida anteriore	Y-103,5 mm	Perfil cierre lona PVC sin embudo PVC canvas closure profile without funnel Profil fermeture toile PVC sans entonnoir Profilo di chiusura del telo PVC senza incavo	Y-104 <sub>(+0/-1)</sub> mm
Perfil guía posterior Back guide profile Profil guide postérieur Profilo guida posterior	Y-103,5 mm	Tubos • Tubes • Tubos • Tubos Ø70/Ø78	X-82 mm

Barra refuerzo acero Ø22 Ø22 steel reinforcement rod Barre renfort acier Ø22 Barra di rinforzo in acciaio Ø22	X<3000 mm	X>3000 mm
	500 mm en cada extremo 500mm at each side 500 mm à chaque extrémité 500 mm ad ogni estremità	650 mm en cada extremo 650mm at each side 650 mm à chaque extrémité 650 mm ad ogni estremità



# NEXUS 100 ZIP GUÍA ESTRECHA

NEXUS 100 ZIP THIN GUIDE • NEXUS 100 ZIP GUIDE ÉTROIT • NEXUS 100 ZIP GUIDA STRETTA

## 04 Preparación de componentes para motor

*Motor hardware preparation*

*Préparation de composants pour moteur*

*Preparazione dei componenti del motore*

### 04.a Confección lona motor • Canvas preparation for motor

*Confection toile moteur • Preparazione telo motore*



### 04.b Mecanizado perfil registro • Upper profile preparation

*Usinage profil registre • Lavorazione dei profili superiori*

**E** Paso 1. Realizar el corte en ambos extremos del perfil.

**GB** Step 1. Cut on both sides of the profile.

**F** 1. Réaliser la découpe sur les deux extrémités du profil.

**I** Fase 1. Effettuare il taglio su entrambe le estremità del profilo.

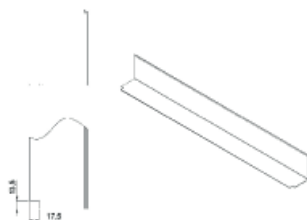

### 04.c Mecanizado perfil guía anterior • Front guide profile preparation

*Usinage profil guide antérieur • Lavorazione del profilo guida anteriore*

**E** Paso 1. Fijación de la guía anterior con la guía posterior.

**GB** Step 1. Attaching the front guide to the back guide.

**F** 1. Fixation du guide antérieur au guide postérieur.

**I** Fase 1. Fissaggio della guida anteriore con la guida posteriore.

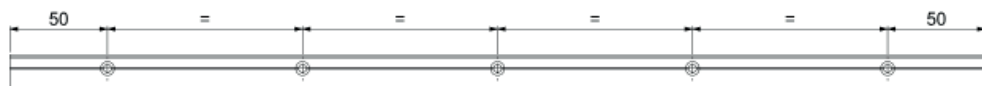
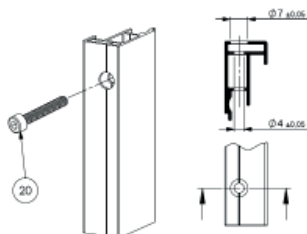

Distancia máxima entre centros: 500 mm • Maximum distance between centres: 500 mm

Distance maximum entre les centres : 500 mm • Distanza massima tra i centri: 500 mm



# NEXUS 100 ZIP GUÍA ESTRECHA

NEXUS 100 ZIP THIN GUIDE • NEXUS 100 ZIP GUIDE ÉTROIT • NEXUS 100 ZIP GUIDA STRETTA



## 04.d Mecanizado perfil cierre lona (opción 1)

*Canvas closure profile preparation (option 1)*

*Usinage profil fermeture toile (option 1)*

*Lavorazione del profilo di chiusura del telo (opzione 1)*

- E** Paso 1. Cortar la guía con forma de embudo para guiar la cremallera.
- GB** Step 1. Cut the guide with a funnel shape to direct the zip.
- F** 1. Couper le guide en forme d'entonnoir pour guider la fermeture éclair.
- I** Fase 1. Tagliare la guida a forma di incavo per collocare la cerniera.

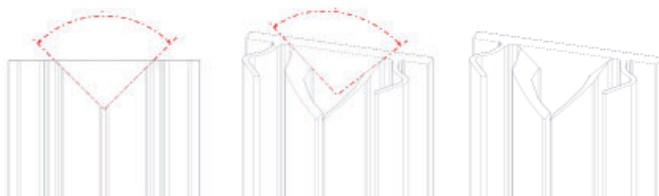
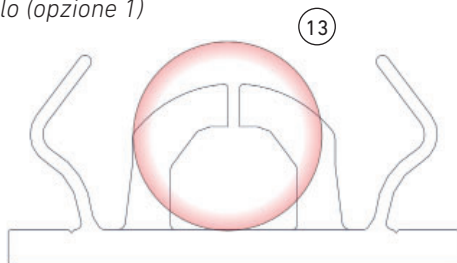

## 04.e Mecanizado perfil cierre lona (opción 2)

*Canvas closure profile preparation (option 2)*

*Usinage profil fermeture toile (option 2)*

*Lavorazione del profilo di chiusura del telo (opzione 2)*

- E** Paso 1. Cortar la zona de la guía indicada en la imagen. Macanizar la guía e insertar el embudo.
- GB** Step 1. Cut the area of the guide shown in the image. Cut the guide and insert the funnel.
- F** 1. Couper la toile du guide indiqué sur l'image. Usiner le guide et insérer l'entonnoir.
- I** Fase 1. Tagliare l'area della guida indicata nell'immagine. Montare la guida e inserire l'incavo.

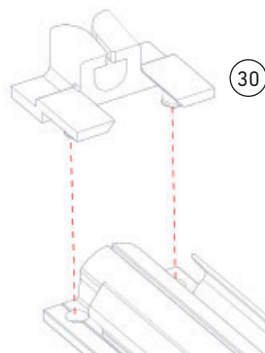
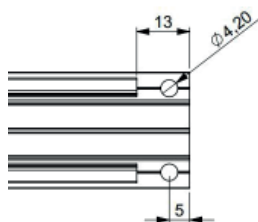
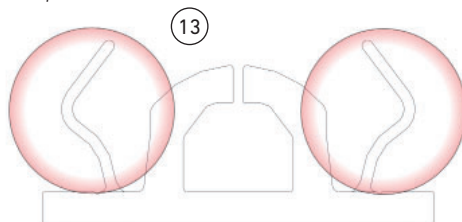



# NEXUS 100 ZIP GUÍA ESTRECHA

NEXUS 100 ZIP THIN GUIDE • NEXUS 100 ZIP GUIDE ÉTROIT • NEXUS 100 ZIP GUIDA STRETTA

## 05 Montaje en fábrica • Factory assembly Montage en usine • Montaggio in fabbrica

### 05.a Montaje felpudo • Brush seal assembly Montage tapis • Montaggio della spazzola a listello

**E** Paso 1. Introducir felpudo en el perfil barra carga.

**GB** Step 1. Insert the brush seal onto the charge profile.

**F** 1. Placer le tapis sur le profil barre charge.

**I** Fase 1. Introdurre la spazzola a listello nel profilo della barra di carico.

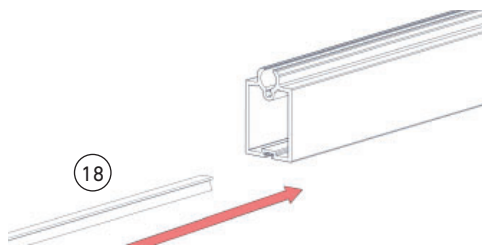

### 05.b Montaje barra refuerzo Ø22 • Ø22 reinforcement rod assembly Montage barre renfort Ø22 • Montaggio della barra di rinforzo Ø22

**E** Paso 1. Introducir barra refuerzo, ver tabla de descuentos.

**GB** Step 1. Insert the reinforcement rod, see cutting table.

**F** 1. Insérer barre renfort, voir tableau de remises.

**I** Fase 1. Inserire la barra di rinforzo (vedi Tabella delle dimensioni).



### 05.c Montaje tapas barra de carga • Charge profile covers assembly Montage couvercles barre de charge • Montaggio dei terminali della barra di carico

**E** Paso 1. Introducir la lona en la barra de carga y posicionar las tapas.

**GB** Step 1. Insert the canvas onto the charge profile and place the covers.

**F** 1. Insérer la toile sur le profil barre de charge et y placer les couvercles.

**I** Fase 1. Collocare il telo sulla barra di carico e posizionare i terminali.

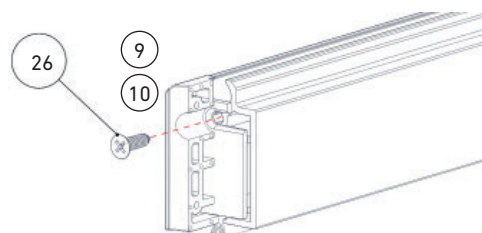

# NEXUS 100 ZIP GUÍA ESTRECHA

NEXUS 100 ZIP THIN GUIDE • NEXUS 100 ZIP GUIDE ÉTROIT • NEXUS 100 ZIP GUIDA STRETTA



- E** Paso 2. Atornillar las tapas a la barra de carga y seguidamente atornillar las tapas entre sí.
- GB** Step 2. Tighten the covers to the charge profile and, then, screw the covers to each other.
- F** 2. Visser les couvercles à la barre de charge puis visser les couvercles entre eux.
- I** Fase 2. Avvitare i terminali alla barra di carico e poi avvitarli tra loro.

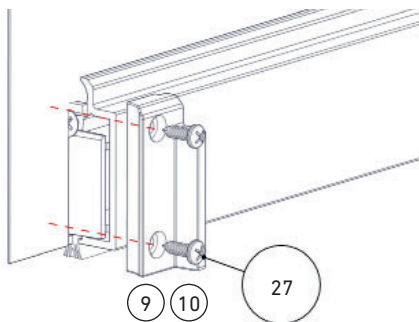

## 05.d Montaje de lona • Canvas assembly Montage de toile • Montaggio del telo

- E** Paso 1. Introducir la lona por la ojiva del tubo y fijar.
- GB** Step 1. Insert the canvas over the tube's ogive and attach.
- F** 1. Introduire la toile par l'ogive du tube et fixer.
- I** Fase 1. Inserire il telo attraverso il tenditore del tubo e fissarlo.

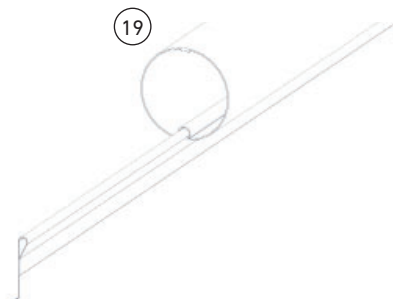

## 05.e Montaje tapas perfil guía • Guide profile cover assembly Montage couvercles profil guide • Assemblaggio dei terminali del profilo guida

- E** Paso 1. Situar la tapa y atornillar.
- GB** Step 1. Place the cover and tighten the screws.
- F** 1. Placer le couvercle et visser.
- I** Fase 1. Posizionare il terminale e avvitare.

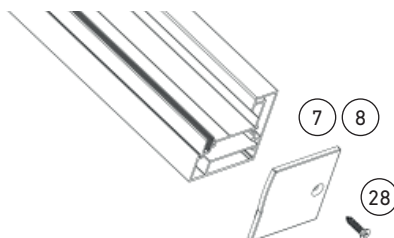



# NEXUS 100 ZIP GUÍA ESTRECHA

NEXUS 100 ZIP THIN GUIDE • NEXUS 100 ZIP GUIDE ÉTROIT • NEXUS 100 ZIP GUIDA STRETTA

## 05.f Montaje de testers • End cap assembly Montage de châssis • Montaggio delle testate

- E** Paso 1. Introducir el felpudo. Situar los testers y atornillar.
- GB** Step 1. Insert the brush seal. Place the end caps and tighten the screws.
- F** 1. Placer le tapis. Ajuster les châssis et visser.
- I** Fase 1. Introdurre la spazzola a listello. Posizionare le testate e avvitare.

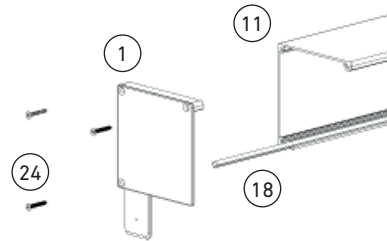

## 06 Montaje en obra • On-site assembly Montage sur site • Montaggio in opera

### 06.a Montaje guía posterior • Back guide assembly Montage guide postérieure • Montaggio della guida posteriore

- E** Paso 1. Situar la guía y atornillar.
- GB** Step 1. Place the guide and tighten the screws.
- F** 1. Placer le guide et visser.
- I** Fase 1. Posizionare la guida e avvitare.

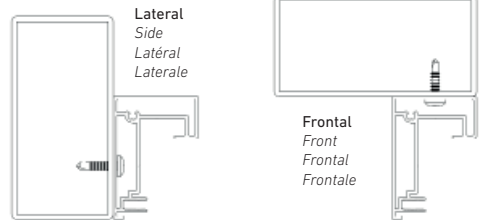

### 06.b Montaje del cajón • Box assembly Montage du coffre • Montaggio del cassonetto

- E** Paso 1. Ensamblar el cajón en las guías introduciendo las patas de los testers en las mismas.
- GB** Step 1. Place the box on the guides, introducing the end cap flaps on them.
- F** 1. Assembler le coffre aux guides en y introduisant les pieds des châssis.
- I** Fase 1. Montare il cassonetto nelle guide inserendo gli ancoraggi delle testate sulle stesse.

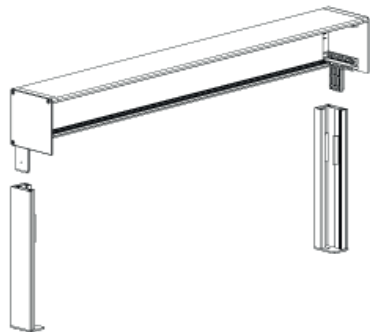

# NEXUS 100 ZIP GUÍA ESTRECHA

NEXUS 100 ZIP THIN GUIDE • NEXUS 100 ZIP GUIDE ÉTROIT • NEXUS 100 ZIP GUIDA STRETTA



## 06.c Montaje del eje • Axis assembly Montage de l'axe • Montaggio dell'asse

- E** Paso 1. Introducir el eje en el perfil cierre lona PVC. Insertar las tuercas cuadradas en los testeros y seguidamente introducir el eje en el interior del cajón deslizando los soportes. Atornillar los soportes a los testeros.
- F** 1. Placer la toile dans le profil fermeture toile PVC. Insérer les écrous carrés dans les châssis puis introduire l'axe à l'intérieur du coffre en faisant glisser les supports. Visser les supports aux châssis.
- GB** Step 1. Insert the canvas on the PVC canvas closure profile. Place the square nuts on the end caps and, then, slide the supports to insert the axis into the box. Tighten the supports to the end caps with screws.
- I** Fase 1. Inserire il telo nel profilo di chiusura del telo PVC. Inserire i dadi quadrati nelle testate, quindi inserire l'asse all'interno del cassonetto facendo scorrere i supporti. Avvitare i supporti alle testate.

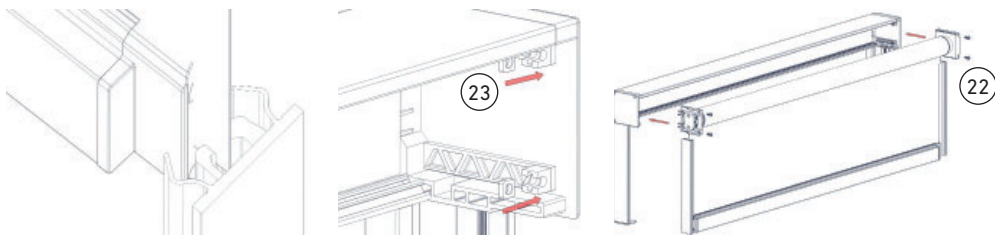

## 06.d Montaje guía anterior y perfil registro Front guide and upper profile assembly Montage guide antérieure et profil registre Montaggio della guida anteriore e del profilo superiore

- E** Paso 1. Introducir la guía anterior y atornillar, seguidamente introducir el perfil registro en el cajón y atornillar.
- F** 1. Introduire la guide antérieure et visser, puis introduire le profil registre dans le coffre et visser.
- GB** Step 1. Insert the front guide and tighten the screws. Then, insert the upper profile in the box and tighten the screws.
- I** Fase 1. Inserire la guida e avvitare, quindi inserire il profilo superiore nel cassonetto e avvitare.

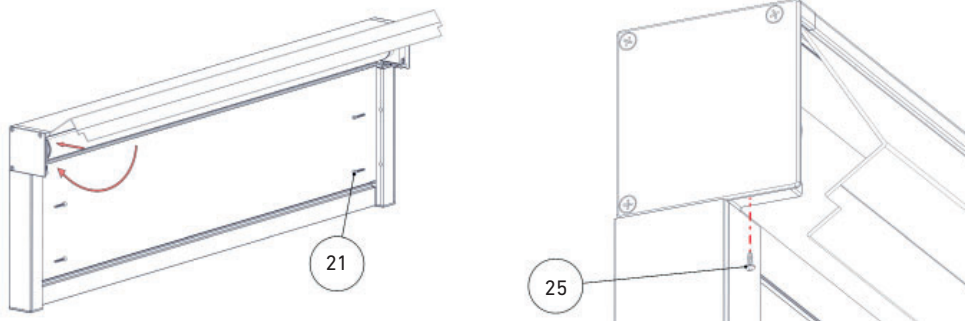







**GAVIOTA**  
Autovía de Alicante, A-31 Km.196  
03630 Sax (Alicante) - España / Spain  
Tel. +34 965 474 200•Fax +34 965 475 680  
International Dept: +34 966 968 276•Fax +34 966 968 075  
comercial@gaviotasimbac.com - export@gaviotasimbac.com  
www.gaviotasimbac.com