

# NEXUS 130 GUÍA

*NEXUS 130 GUIDE*

*NEXUS 130 GUIDE*

*NEXUS 130 GUIDA*



**gaviota**  
The Sun & Shutter Specialists



**E** **Manual de Instalación**

**F** *Manuel d'Installation*

**GB** *Assembly Instructions*

**I** *Manuale di Installazione*





## E Advertencias de seguridad

### GB Safety warnings

## F Avertissement de sécurité

### I Avvertenze e note di sicurezza

- E** • Leer detenidamente estas instrucciones de montaje antes de cualquier uso y conservarlas después de la instalación..
- E** • El no respetar las instrucciones de montaje, uso y especificaciones técnicas del artículo, así como excederse en los rangos de uso máximos especificados (pesos, etc...), significará la exclusión de la Política de Garantía y de Servicio Postventa de Gaviota Simbac, S.L.
- GB** • Read carefully the assembly instructions before installing the awning.
- GB** • Failure to follow the assembly instructions, use conditions and technical specifications of the article, as well as exceeding the specified maximum use ranges (weights, etc ...), will mean the exclusion of the Warranty and After Sales Service Policy of Gaviota Simbac, S.L.
- F** • Lire attentivement les instructions de montage avant de procéder à l'installation du store.
- F** • *maximus spécifiés (poids, etc...), sera motif d'exclusion de la Politique de Garantie et Service Après-vente de Gaviota Simbac, S.L. Leggere queste istruzioni prima dell'uso e conservarle l'installazione.*
- I** • Leggere attentamente le istruzioni di montaggio prima di montare la tenda da sole.
- I** • La mancata osservanza delle istruzioni per il montaggio, l'uso, le specifiche tecniche di questo articolo, e degli intervalli che superano il massimo utilizzo specificato (pesi, ecc ...), significherà l'esclusione della Politica della Garanzia e Servizio Post-Vendita GAVIOTA SIMBAC, S.L.

## Índice • Index • Index • Indice

- 01** **Listado de componentes para motor • Motor hardware list**  
*Liste de composants pour moteur • Elenco dei componenti per motore*
- 02** **Explosionados motor • Motor exploded view**  
*Exposition pièces moteur • Grafico esploso del motore*
- 03** **Rango de uso y descuentos. Motor • Range of use & cutting table. Motor**  
*Gamme d'utilisation et remises. Moteur • Intervallo d'uso e dimensioni. Motore*
- 04** **Preparación de componentes para motor • Motor hardware preparation**  
*Préparation de composants pour moteur • Preparazione dei componenti del motore*
- 05** **Listado de componentes para cardán • Cardan hardware list**  
*Liste de composants pour cardan • Elenco dei componenti per cardano*
- 06** **Explosionados cardán • Cardan exploded view**  
*Exposition pièces cardan • Grafico esploso del cardano*
- 07** **Rango de uso y descuentos. Cardán • Range of use & cutting table. Cardan**  
*Gamme d'utilisation et remises. Cardan • Intervallo d'uso e dimensioni. Cardano*
- 08** **Preparación de componentes para cardán • Cardan hardware preparation**  
*Préparation de composants pour cardan • Preparazione dei componenti per cardano*
- 09** **Montaje del cardán • Cardan assembly**  
*Montage du cardan • Montaggio del cardano*
- 10** **Montaje en fábrica • Factory assembly**  
*Montage en usine • Montaggio in fabbrica*
- 11** **Montaje en obra • On-site assembly**  
*Montage sur site • Montaggio in opera*



# NEXUS 130 GUÍA

NEXUS 130 GUIDE • NEXUS 130 GUIDE • NEXUS 130 GUIDA

01

## Listado de componentes para motor • Motor hardware list

Liste de composants pour moteur • Elenco dei componenti per motore

Nº	Código Code	Artículo • Article
1a	80170921	Juego Testeros Screen Nexus 130 blanco • Screen Nexus 130 end cap set white
1b	80170927	Juego Testeros Screen Nexus Curve 130 blanco • Screen Nexus Curve 130 end cap set white
2	80170010	Soporte lateral Ø50 Screen Rits • Ø50 Screen Rits lateral support
3a	80170530	Soporte New lateral motor Gaviota screen Rits • Screen Rits Gaviota motor new lateral support
3b	80170009	Soporte New lateral motor Somfy screen Rits • Somfy motor Screen Rits lateral support
3c	80170962	Soporte lateral multimotor screen Rits • Screen Rits multimotor lateral support
3d	80170941	Soporte lateral motor Elite-i • Elite-i motor lateral support
4a	80170147	Casquillo adaptador polea Ø70 Screen Rits • Ø70 Screen Rits pulley adaptor bearing
4a	80170485	Casquillo adaptador polea Ø70 motor Somfy • Ø70 Somfy motor pulley adaptor bearing
4b	80170011	Casquillo adaptador polea Ø78 Screen Rits • Ø78 Screen Rits pulley adaptor bearing
4b	80170486	Casquillo adaptador polea Ø78 motor Somfy • Ø78 Somfy motor pulley adaptor bearing
4c	80170721	Casquillo adaptador polea Ø85 Screen Rits • Ø85 Screen Rits pulley adaptor bearing
4c	80170487	Casquillo adaptador polea Ø85 motor Somfy • Ø85 Somfy motor pulley adaptor bearing
5a	60070059	Coronas para eje Ø70 ojiva S45 Gaviota • Gears for Ø70 ogive axis S45 Gaviota
5b	60070060	Corona para eje Ø78 ojiva S45 Gaviota • Gears for Ø78 ogive axis S45 Gaviota
5c	60070076	Corona para eje Ø85 ojiva S45 Gaviota • Gears for Ø85 ogive axis S45 Gaviota
6a	80170012	Anillo fijación Screen Rits • Screen Rits fixation ring
6b	80170942	Anillo fijación motor Elite-i Screen Nexu • Elite-i motor Screen Nexus fixation ring
7	80170937	Tapa barra carga para guía Nexus 130 blanco • Nexus 130 Guide Charge profile cover white
8	80170951	Juego de tapas guía Screen Nexus blanco • Screen Nexus Guide cover set white
9	60050232	Motor Elite-i 20/15 cabeza 9mm S45 • Elite-i 20/15 motor 9mm head S45
10	80170906	Perfil cajón para Screen Nexus 130 blanco 7m • Box profile for Screen Nexus 130 white 7m
11a	80170912	Perfil registro Screen Nexus 130 blanco 7m • Screen Nexus 80 Upper profile white 7m
11b	80170915	Perfil registro Screen Nexus Curve 130 blanco 7m • Screen Nexus Curve 80 Upper profile white 7m
12	80170918	Perfil Barra Carga Screen Nexus 130 blanco 7m • Screen Nexus 130 Charge profile white 7m
13	80170854	Perfil guía Screen Nexus blanco 7m • Screen Nexus Guide profile white 7m
14	80170054	Felpudo pb-48-800-3pb cortado a 5m Screen • Brush seal pb-48-800-3pb cut at 5m screen
15a	80030024	Tubo ranurado ojiva Ø70x1 4m • Threaded tube with ogive Ø70x1 4m
15b	80030020	Tubo ranurado ojiva Ø78x1 4m • Threaded tube with ogive Ø78x1 4m
15c	80030050	Tubo ranurado ojiva rizado Ø85x1,2 soldado 5m • Threaded tube ridged with ogive Ø85x1.2 welded 5m
16	80170055	Barra refuerzo Ø22 Screen Rits zincada 4m • Ø22 Screen Rits galvanised reinforcement rod 4m
	80170947	Bolsa tornillería Screen Nexus 130 guía • Screen Nexus 130 guide hardware bag
17		Tornillo rosca chapa 4,2x50 DIN-7982 DACRO • Self-drilling screw 4,2x50 DIN-7982 DACRO
18		Tornillo cabeza alom M4x10 DIN-7985 inox A2 • Pan head screw M4x10 DIN-7985 SS A2
19		Tuerca cuadrada M4 DIN-562 inox A2 • Square nut M4 DIN-562 SS A2
20		Tornillo Ø3,5x6,5 DIN-7981 inox A2 • Screw Ø3,5x6,5 DIN-7981 SS A2
21		Tornillo Ø3,5x16 DIN-7982 inox A2 • Screw Ø3,5x16 DIN-7982 SS A2
22		Tornillo M6x14 DIN-7991 inox A2 • Screw M6x14 DIN-7991 SS A2
23		Clip perfil guía Screen Universal • Screen Universal Guide profile clip
24		Tornillo Ø4,2x25 DIN-7982 inox A2 • Screw Ø4,2x25 DIN-7982 SS A2



N°	Code Codice	Article • Articolo
1a	80170921	<i>Jeu châssis Screen Nexus 130 blanc • Kit di testate Screen Nexus 130 bianco</i>
1b	80170927	<i>Jeu châssis Screen Nexus 130 blanc • Kit di testate Screen Nexus Curve 130 bianco</i>
2	80170010	<i>Support latéral Ø50 Screen Rits • Supporto laterale Ø50 Screen Rits</i>
3a	80170530	<i>Support new latéral moteur Gaviota Screen Rits • Nuovo supporto motore laterale Gaviota Screen Rits</i>
3b	80170009	<i>Support latéral moteur Somfy Screen Rits • Supporto laterale motore Somfy Screen Rits</i>
3c	80170962	<i>Support latéral multimoteur Screen Rits • Supporto laterale plurimotore Screen Rits</i>
3d	80170941	<i>Support latéral moteur Elite-i Screen Nexus • Supporto laterale motore Elite-i</i>
4a	80170147	<i>Culot adaptateur poulie Ø70 Screen Rits • Boccola adattatore puleggia Ø70 Screen Rits</i>
4a	80170485	<i>Culot adaptateur poulie Ø70 moteur Somfy • Boccola adattatore puleggia Ø70 motore Somfy</i>
4b	80170011	<i>Culot adaptateur poulie Ø78 Screen Rits • Boccola adattatore puleggia Ø78 Screen Rits</i>
4b	80170486	<i>Culot adaptateur poulie Ø78 moteur Somfy • Boccola adattatore puleggia Ø78 motore Somfy</i>
4c	80170721	<i>Culot adaptateur poulie Ø85 Screen Rits • Boccola adattatore puleggia Ø85 Screen Rits</i>
4c	80170487	<i>Culot adaptateur poulie Ø78 moteur Somfy • Boccola adattatore puleggia Ø85 motore Somfy</i>
5a	60070059	<i>Couronnes pour axe Ø70 ogive S45 Gaviota • Adattatori per asse Ø70 tenditore S45 Gaviota</i>
5b	60070060	<i>Couronnes pour axe Ø78 ogive S45 Gaviota • Adattatori per asse Ø78 tenditore S45 Gaviota</i>
5c	60070076	<i>Couronnes pour axe Ø85 ogive S45 Gaviota • Adattatori per asse Ø85 tenditore S45 Gaviota</i>
6a	80170012	<i>Anneau fixation Screen Rits • Anello di fissaggio Screen Rits</i>
6b	80170942	<i>Anneau fixation moteur Elite-i Screen Nexus • Anello di fissaggio motore Elite-i Screen Nexus</i>
7	80170937	<i>Couvercle barre charge pour guide Nexus 130 blanc • Terminale della barra di carico per guida Screen Nexus 130 bianco</i>
8	80170951	<i>Jeu de couvercles guide Screen Nexus blanc • Kit di terminali guida Screen Nexus bianco</i>
9	60050232	<i>Moteur Elite-i 20/15 tête 9mm S45 • Motore Elite-i 20/15 testa 9 mm S45</i>
10	80170906	<i>Profil coffre pour Screen Nexus 130 blanc 7m • Profilo del cassonetto Screen Nexus 130 bianco 7 m</i>
11a	80170912	<i>Profil registre Screen Nexus 80 blanc 7mm • Profilo superiore Screen Nexus 80 bianco 7 m</i>
11b	80170915	<i>Profil registre Screen Nexus Curve 80 blanc 7m • Profilo superiore Screen Nexus Curve 80 bianco 7 m</i>
12	80170918	<i>Profil barre chargement Screen Nexus 130 blanc 7m • Profilo della barra di carico Screen Nexus 130 bianco 7 m</i>
13	80170854	<i>Profil guide Screen Nexus blanc 7m • Profilo guida Screen Nexus bianco 7 m</i>
14	80170054	<i>Tapis pb-48-800-3pb coupé à 5m Screen • Spazzola a listello pb-48-800-3pb tagliata a 5 m Screen</i>
15a	80030024	<i>Tube rainuré ogive Ø70x1 4m • Tubo scanalato tenditore Ø70x1 4 m</i>
15b	80030020	<i>Tube rainuré ogive Ø78x1 4m • Tubo scanalato tenditore Ø78x1 4 m</i>
15c	80030050	<i>Câble Screen Ø5, 1x19, aisi 316 bobine 20mm • Tubo scanalato tenditore avvolgibile Ø85x1,2 soldato 5 m</i>
16	80170055	<i>Barre renfort Ø22 Screen Rits zinguée 4m • Barra di rinforzo Ø22 Screen Rits zincata 4 m</i>
	<b>80170947</b>	<b><i>Sac boulonnerie Screen Nexus 130 guide • Contenitore bulloneria Screen Nexus 130 guida</i></b>
17		<i>Vis à tête 4,5x22 DIN-7982 Dacro • Vite per lamiera 4,2x50 DIN-7982 Dacro</i>
18		<i>Vis tête Alom M4x10 DIN-7985 inox A2 • Vite a testa bombata M4x10 DIN-7985 inox A2</i>
19		<i>Écrou carré M4 DIN-562 inox A2 • Dado quadrato M4 DIN-562 inox A2</i>
20		<i>Vis Ø3,5x6,5 DIN-7981 inox A2 • Vite Ø3,5x6,5 DIN-7981 inox A2</i>
21		<i>Vis Ø3,5x16 DIN-7982 inox A2 • Vite Ø3,5x16 DIN-7982 inox A2</i>
22		<i>Vis M6x10 DIN-7991 inox A2 70 • Vite M6x14 DIN-7991 inox A2</i>
23		<i>Clip profil Screen Universal • Tassello profilo guida Screen Universal</i>
24		<i>Vis Ø4,2x25 DIN-7982 inox A2 • Vite Ø4,2x25 DIN-7982 inox A2</i>



# NEXUS 130 GUÍA

NEXUS 130 GUIDE • NEXUS 130 GUIDE • NEXUS 130 GUIDA

## 02

### Explosionados motor • Motor exploded view Exposition pièces moteur • Grafico esploso del motore

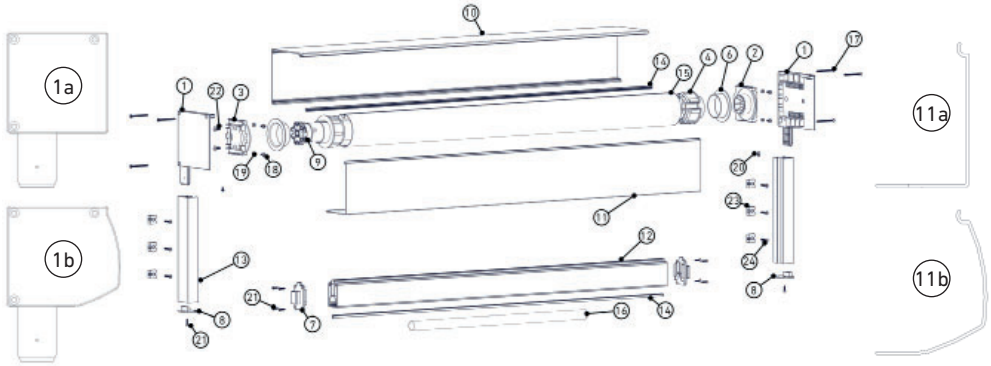

#### Despiece eje motor

Motor axis exploded view  
Démontage axe moteur  
Vista esplosa dell'asse motore

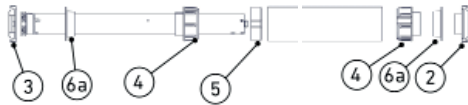

En el lado del motor 3a, 3b, 3c o 3d: según el tipo de motor.  
On the side of the motor, 3a, 3b, 3c or 3d: depending on the motor.  
Sur le côté du moteur, 3a, 3b, 3c ou 3d, selon le type de moteur.  
Sul lato del motore, 3a, 3b, 3c o 3d: a seconda del tipo di motore.

#### Despiece eje multimotor

Multimotor axis exploded view  
Démontage axe multimoteur  
Vista esplosa dell'asse plurimotore

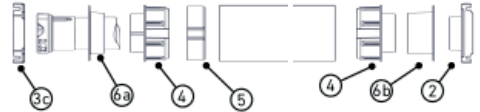

#### Despiece eje motor Elite-i

Elite-i motor axis exploded view  
Démontage axe moteur Elite-i  
Vista esplosa dell'asse motore Elite-i

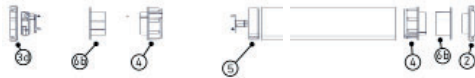

#### Para todos los ejes • For all axes

Pour tous les axes • Para todos los ejes

4a, 4b, 4c, 5a, 5b o 5c: según el Ø del tubo.

4a, 4b, 4c, 5a, 5b or 5c: depending on tube Ø.

4a, 4b, 4c, 5a, 5b ou 5c, selon le Ø du tube.

4a, 4b, 4c, 5a, 5b o 5c: a seconda del Ø del tubo.

03

**Rango de uso y descuentos. Motor** • Range of use & cutting table. Motor  
Gamme d'utilisation et remises. Moteur • Intervallo d'uso e dimensioni. Motore



Tabla de descuentos motor cabeza 9mm Cutting table for 9mm head motor Tableau de remises moteur tête 9mm Tabella delle dimensioni motore testa 9 mm	
Perfil cajón • Box profile Profil coffre • Profilo del cassonetto	X-32 mm
Perfil registro • Upper profile Profil registre • Profilo superiore	X-6 <sub>(+0/-0,5)</sub> mm
Perfil guía • Guide profile Profil guide • Profilo guida	Y-133,5 mm
Perfil barra carga • Charge profile Profil barre charge Profilo della barra di carico	X-75 <sub>(±0,5)</sub> mm
Tubos • Tubes • Tubes • Tubos Ø70/Ø78/Ø85	X-84 mm

Tabla de descuentos multimotor/Elite-i Multimotor/Elite-i cutting table Tableau de remises multimoteur /Elite-i Tabella delle dimensioni plurimotore/Elite-i	
Perfil cajón • Box profile Profil coffre • Profilo del cassonetto	X-32 mm
Perfil registro • Upper profile Profil registre • Profilo superiore	X-6 <sub>(+0/-0,5)</sub> mm
Perfil guía • Guide profile Profil guide • Profilo guida	Y-133,5 mm
Perfil barra carga • Charge profile Profil barre charge Profilo della barra di carico	X-75 <sub>(±0,5)</sub> mm
Tubos • Tubes • Tubes • Tubos Ø70/Ø78/Ø85	X-117 mm

Rango de uso clase III Range of use: class III Gamme d'utilisation catégorie III Intervallo d'uso classe III		
Tubo • Tube Tube • Tubo	X máxima • maximum maximum • Max.	Y máxima • maximum maximum • Max.
Ø70	4000	3500
Ø78	4000	2700
Ø85	5000	5000

Barra refuerzo acero Ø22 Ø22 steel reinforcement rod Barre renfort acier Ø22 Barra di rinforzo in acciaio Ø22	X<3000 mm	X>3000 mm
	500 mm en cada extremo 500mm at each side 500 mm à chaque extrémité 500 mm ad ogni estremità	650 mm en cada extremo 650mm at each side 650 mm à chaque extrémité 650 mm ad ogni estremità

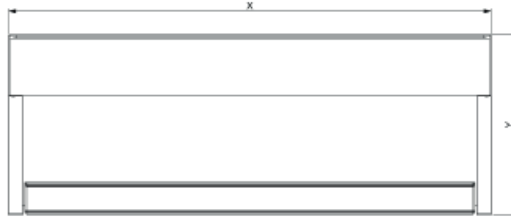

# NEXUS 130 GUÍA

NEXUS 130 GUIDE • NEXUS 130 GUIDE • NEXUS 130 GUIDA

## 04 Preparación de componentes para motor

*Motor hardware preparation*

*Préparation de composants pour moteur*

*Preparazione dei componenti del motore*

### 04.a Confección lona motor

*Canvas preparation for motor*

*Confection toile moteur*

*Preparazione telo motore*

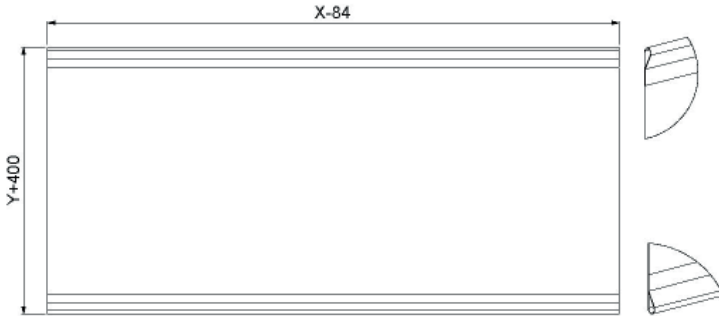

### 04.b Mecanizado perfil registro • Upper profile preparation

*Usinage profil registre • Lavorazione dei profili superiori*

**E** Paso 1. Realizar el corte en ambos extremos del perfil.

**GB** Step 1. Cut on both sides of the profile.

**F** 1. Réaliser la découpe sur les deux extrémités du profil.

**I** Fase 1. Effettuare il taglio su entrambe le estremità del profilo.

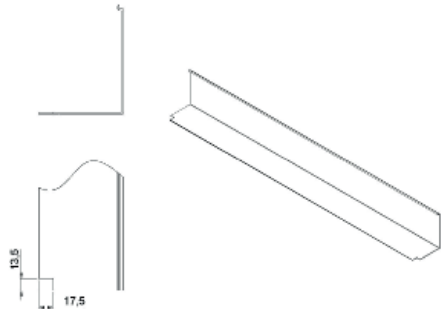



## 05 Listado de componentes para cardán • Cardan hardware list Liste de composants pour cardan • Elenco dei componenti per cardano

Nº	Código Code Codice	Artículo • Article • Article • Articolo
	<b>80170963</b>	<b>Kit para cardán • Cardan kit • Kit pour cardan • Kit per cardano</b>
25		Tornillo M5x30 DIN 7991 inox A2 • Screw M5x30 DIN7991 SS A2 Vis M5x30 DIN7991 inox A2 • Vite M5x30 DIN 7991 inox A2
26		Soporte lateral cardán screen Nexus • Screen Nexus cardan lateral support Support latéral cardan Screen Nexus • Supporto laterale cardano Screen Nexus
27		Tuerca autoblocante M5 DIN980 V inox A4 • Locknut M5 DIN980 V SS A4 Écrou autobloquant M5 DIN980 V inox A4 • Dado autobloccante M5 DIN980 V inox A4
28		Anillo distanciador 13 cardán screen Nexus • Screen Nexus Spacer ring 13 cardan Anneau d'écartement 13 cardan screen Nexus • Anello distanziatore 13 cardano Screen Nexus
29		Inserto metálico 13x7 screen Universal Zip • Screen Universal Zip 13x7 Metallic insert Insert métallique 13x7 screen Universal Zip • Inserto metallico 13x7 Screen Universal Zip
30	70100343	Mecanismo cardán 1420 R=5:1 Ø7/13 CFC • Cardan mechanism 1420 R=5:1 Ø7/13 CFC Mécanisme cardan 1420 R=5:1 Ø7/13 CFC • Meccanismo cardano 1420 R=5:1 Ø7/13 CFC
31a	80020024	Casquillo 70 ran plástico Transmisión 13 screen Zip • Screen Zip 70 plastic groove gear transmission 13 Douille 70 rainure plastique Transmission 13 screen Zip • Boccola 70 scanalatura di plastica trasmissione 13 Screen Zip
31b	80020025	Casquillo 78 ran plástico Transmisión 13 screen Zip • Screen Zip 78 plastic groove gear transmission 13 Douille 78 rainure plastique Transmission 13 screen Zip • Boccola 78 scanalatura di plastica trasmissione 13 Screen Zip
32	70100551	Snodo 45-35 Zamak 2T Ø7 Aluminio níquelada Ø14 • Snodo 45-35 Zamak 2T Ø7 nickel-plated aluminium Ø14 Coussinet sphérique 45-35 Zamak 2T Ø7 Aluminium nickelé Ø14 • Snodo 45-35 zamak 2T Ø7 alluminio nichelato Ø14

## 06 Explosionados cardán • Cardan exploded view Exposition pièces cardan • Grafico esploso del cardano

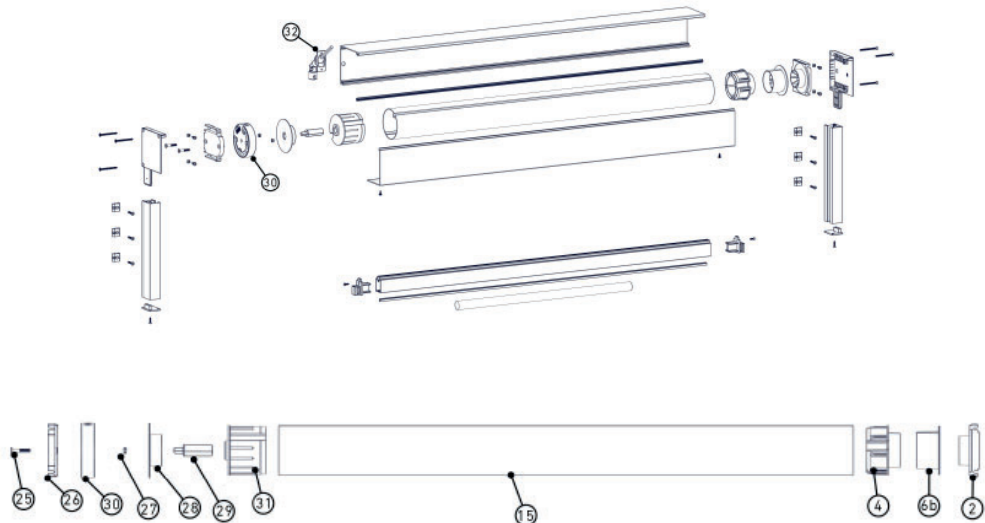

31a o 31b: según el Ø del tubo • 31a or 31b: depending on tube Ø  
31a ou 31b, selon le Ø du tube • 31a o 31b: a seconda del tubo.



# NEXUS 130 GUÍA

NEXUS 130 GUIDE • NEXUS 130 GUIDE • NEXUS 130 GUIDA

## 07

**Rango de uso y descuentos. Cardán** • Range of use & cutting table. Cardan  
Gamme d'utilisation et remises. Cardan • Intervallo d'uso e dimensioni. Cardano



Tabla de descuentos para cardán Cardan cutting table Tableau de remises cardan Tabella delle dimensioni cardan	
Perfil cajón • Box profile Profil coffre • Profilo del cassonetto	X-32 mm
Perfil registro • Upper profile Profil registre • Profilo superiore	X-6 <sub>(+0/-0,5)</sub> mm
Perfil guía • Guide profile Profil guide • Profilo guida	Y-133,5 mm
Perfil barra carga • Charge profile Profil barre charge Profilo della barra di carico	X-75 <sub>(±0,5)</sub> mm
Tubos • Tubes • Tubes • Tubos Ø70/Ø78/Ø85	X-117 mm

Rango de uso clase III Range of use: class III Gamme d'utilisation catégorie III Intervallo d'uso classe III		
Tubo • Tube Tube • Tubo	X máxima • maximum maximum • Max.	Y máxima • maximum maximum • Max.
Ø70	4000	3500
Ø78	4000	2700
Ø85	5000	5000

Barra refuerzo acero Ø22 Ø22 steel reinforcement rod Barre renfort acier Ø22 Barra di rinforzo in acciaio Ø22	X<3000 mm	X>3000 mm
	500 mm en cada extremo 500mm at each side 500 mm à chaque extrémité 500 mm ad ogni estremità	650 mm en cada extremo 650mm at each side 650 mm à chaque extrémité 650 mm ad ogni estremità

Eje Axis Axe Rullo Ø70	1,00	1,50	2,00	2,50	3,00	3,50	4,00	X	Y
	R1/5	R1/5	R1/5					3,25	
	R1/5	R1/5	R1/5	R1/5				3,00	
	R1/5	R1/5	R1/5	R1/5	R1/5			2,75	
	R1/5	R1/5	R1/5	R1/5	R1/5			2,50	
	R1/5	R1/5	R1/5	R1/5	R1/5			2,25	
	R1/5	R1/5	R1/5	R1/5	R1/5			2,00	
	R1/5	R1/5	R1/5	R1/5	R1/5			1,50	
	R1/5	R1/5	R1/5	R1/5	R1/5			1,00	

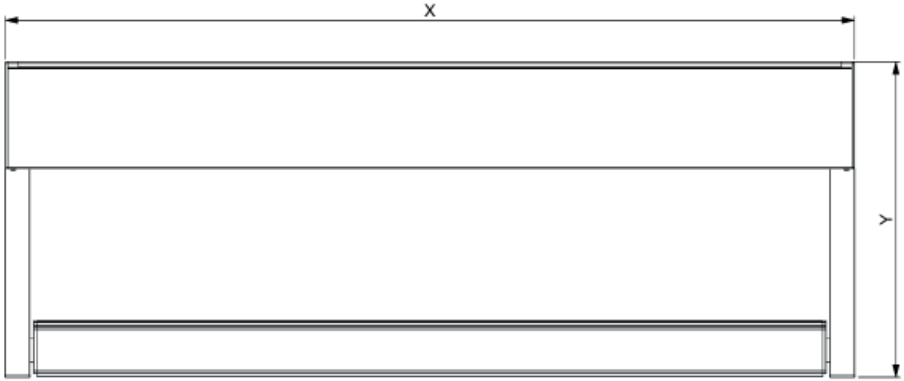
Eje Axis Axe Rullo Ø78	1,00	1,50	2,00	2,50	3,00	3,50	4,00	X	Y
	R1/5	R1/5	R1/5					2,70	
	R1/5	R1/5	R1/5					2,50	
	R1/5	R1/5	R1/5	R1/5				2,00	
	R1/5	R1/5	R1/5	R1/5	R1/5			1,50	
	R1/5	R1/5	R1/5	R1/5	R1/5			1,00	

## 08 Preparación de componentes para cardán

*Cardan hardware preparation*

*Préparation de composants pour cardan*

*Preparazione dei componenti per cardano*

### 08.a Confección lona para cardán

*Canvas preparation for cardan*

*Confection toile pour cardan*

*Preparazione telo per cardano*

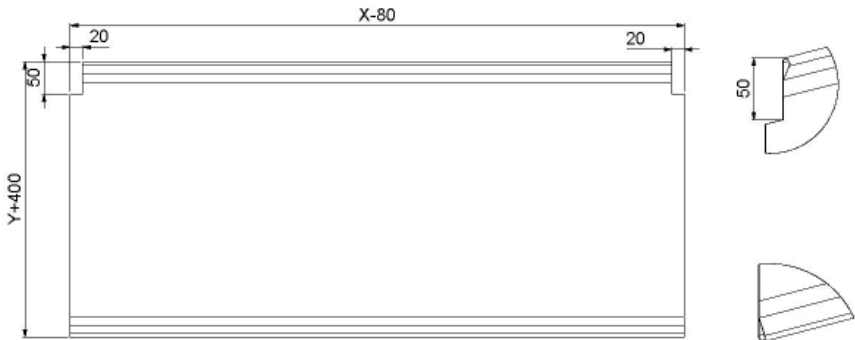

### 08.b Mecanizado perfil cajón para cardán • Box profile preparation for cardan

*Usinage coffre pour cardan • Lavorazione del profilo del cassonetto per cardano*

**E** Paso 1. Realizar el taladro como se indica en la imagen.

**F** 1. Réaliser la perforation comme indiqué sur l'image.

**GB** Step 1. Drill as shown in the image.

**I** Fase 1. Trapanare come si indica nell'immagine.

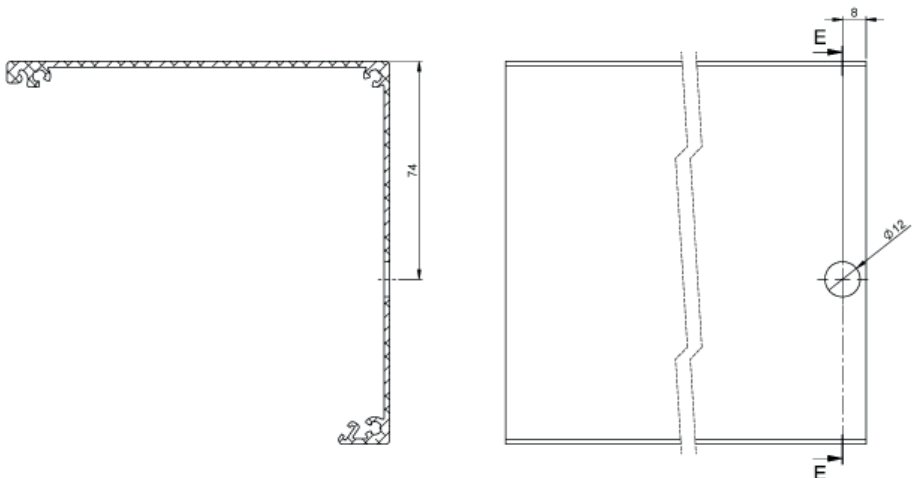



# NEXUS 130 GUÍA

NEXUS 130 GUIDE • NEXUS 130 GUIDE • NEXUS 130 GUIDA

09

## Montaje del cardán • Cardan assembly

Montage du cardan • Montaggio del cardano

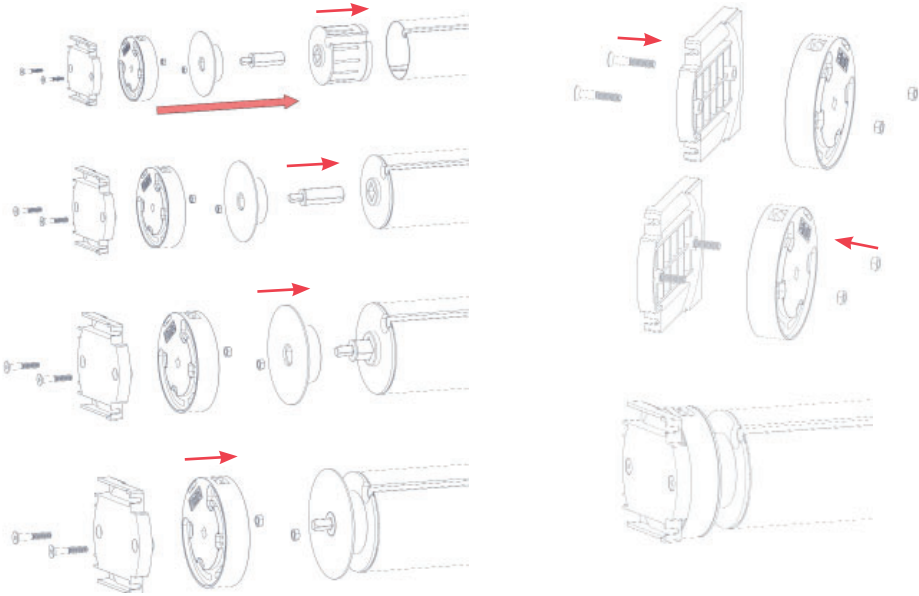

09.a

## Montaje del snodo • Snodo assembly

Montage du coussinet sphérique • Montaggio dello snodo

**E** Paso 1. Introducir el snodo del cardán por el agujero mecanizado en la parte trasera del cajón.

**GB** Step 1. Insert the snodo in the cardan through the hole drilled at the back of the box.

**F** 1. Introduire le coussinet sphérique du cardan dans le trou usiné sur la partie arrière du coffre.

**I** Fase 1. Inserire lo snodo del cardano attraverso il foro ricavato nella parte posteriore del cassonetto.



## 10 Montaje en fábrica • Factory assembly Montage en usine • Montaggio in fabbrica

### 10.a Montaje felpudo • Brush seal assembly Montage tapis • Montaggio della spazzola a listello

- E** Paso 1. Introducir felpudo en el perfil barra carga.
- GB** Step 1. Insert the brush seal onto the charge profile.
- F** 1. Placer le tapis sur le profil barre charge.
- I** Fase 1. Introdurre la spazzola a listello nel profilo della barra di carico.

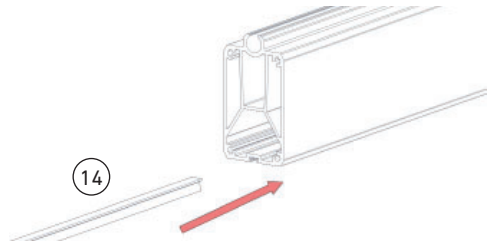

### 10.b Montaje barra refuerzo Ø22 • Ø22 reinforcement rod assembly Montage barre renfort Ø22 • Montaggio della barra di rinforzo Ø22

- E** Paso 1. Introducir barra refuerzo, ver tabla de descuentos.
- GB** Step 1. Insert the reinforcement rod, see cutting table.
- F** 1. Insérer barre renfort, voir tableau de remises.
- I** Fase 1. Inserire la barra di rinforzo (vedi Tabella delle dimensioni).



### 10.c Montaje tapas barra de carga • Charge profile covers assembly Montage couvercles barre de charge • Montaggio dei terminali della barra di carico

- E** Paso 1. Introducir la lona en la barra de carga y posicionar las tapas. Atornillar las tapas a la barra de carga.
- GB** Step 1. Insert the canvas onto the charge profile and place the covers. Tighten the covers to the charge profile.
- F** 1. Insérer la toile sur le profil barre de charge et y placer les couvercles. Visser les couvercles à la barre de charge.
- I** Fase 1. Collocare il telo sulla barra di carico e posizionare i terminali. Avvitare i terminali alla barra di carico.

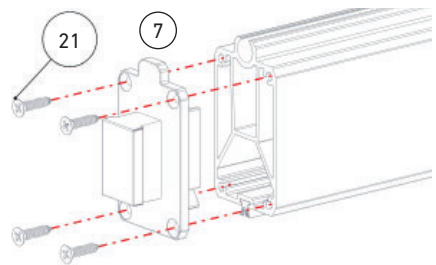



# NEXUS 130 GUÍA

NEXUS 130 GUIDE • NEXUS 130 GUIDE • NEXUS 130 GUIDA

## 10.d Montaje de lona • Canvas assembly Montage de toile • Montaggio del telo

- E** Paso 1. Introducir la lona por la ojiva del tubo y fijar.
- GB** Step 1. Insert the canvas over the tube's ogive and attach.
- F** 1. Introduire la toile par l'ogive du tube et fixer.
- I** Fase 1. Inserire il telo attraverso il tenditore del tubo e fissarlo.

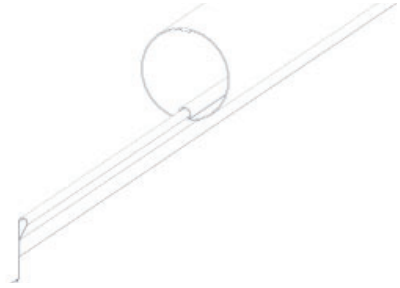

## 10.e Montaje tapas perfil guía • Guide profile cover assembly Montage couvercles profil guide • Assemblaggio dei terminali del profilo guida

- E** Paso 1. Situar la tapa y atornillar.
- GB** Step 1. Place the cover and tighten the screws.
- F** 1. Placer le couvercle et visser.
- I** Fase 1. Posizionare il terminale e avvitare.

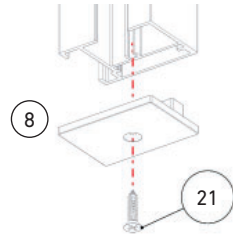

## 10.f Montaje de testereros • End cap assembly Montage de châssis • Montaggio delle testate

- E** Paso 1. Introducir el felpudo. Situar los testereros y atornillar.
- GB** Step 1. Insert the brush seal. Place the end caps and tighten the screws.
- F** 1. Placer le tapis. Ajuster les châssis et visser.
- I** Fase 1. Introdurre la spazzola a listello. Posizionare le testate e avvitare.

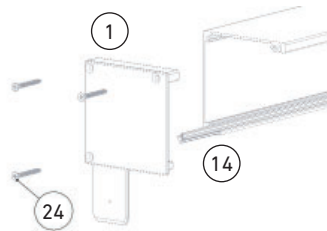

## 11 Montaje en obra • On-site assembly Montage sur site • Montaggio in opera

### 11.a Montaje guía • Guide assembly Montage guide • Montaggio della guida

**E** Paso 1. Situar los clips en la pared y atornillar (una cada 500mm). A continuación, presionar la guía contra éstos para fijarla.

**GB** Step 1. Place the clips on the wall and tighten the screws (each one at 500 mm). Then, press the guide against them to fasten.

**F** 1.

Placer les clips au mur et en visser un tous les 500mm. Ensuite, appuyer le guide contre les clips pour le fixer.

**I** Fase 1.

Posizionare i tasselli sulla parete e avvitarli (uno ogni 500 mm). Quindi premere la guida contro di loro per fissarla.

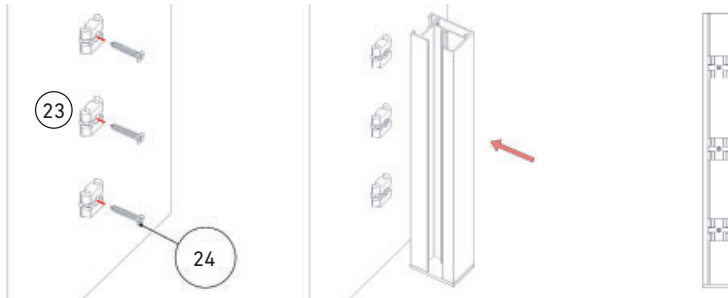

### 11.b Montaje barra de carga en las guías • Assembly of charge profile on guides Montage barre de charge sur les guides • Montaggio della barra di carico nelle guide

**E** Paso 1. Insertar las tapas de la barra de carga por las guías.

**GB** Step 1. Insert the charge profile covers through the guides.

**F** 1. Insérer les couvercles de la barre de charge sur les guides.

**I** Fase 1. Inserire i terminali della barra di carico sulle guide.

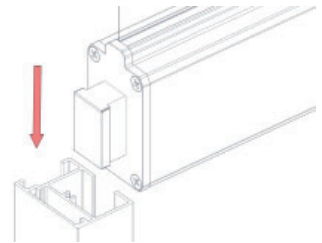



# NEXUS 130 GUÍA

NEXUS 130 GUIDE • NEXUS 130 GUIDE • NEXUS 130 GUIDA

## 11.c Montaje del cajón • Box assembly Montage du coffre • Montaggio del cassonetto

- E** Paso 1. Ensamblar el cajón en las guías introduciendo las patas de los testeros en las mismas.
- GB** Step 1. Place the box on the guides, introducing the end cap flaps on them.
- F** 1. Assembler le coffre aux guides en y introduisant les pieds des châssis.
- I** Fase 1. Montare il cassonetto nelle guide inserendo gli ancoraggi delle testate sulle stesse.

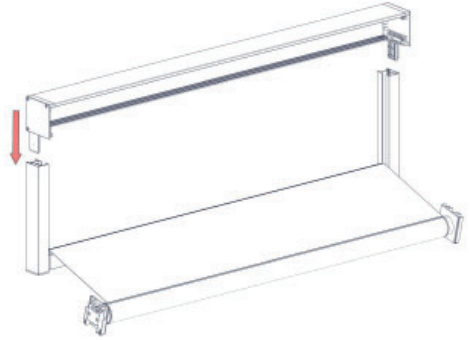

## 11.d Montaje del eje • Axis assembly Montage de l'axe • Montaggio dell'asse

- E** Paso 1. Situar las tuercas en los testeros. Introducir el eje en el interior del cajón deslizando los soportes entre la guía de los testeros. Atornillar los soportes a los testeros.
- F** 1. Placer les écrous sur les châssis. Introduire l'axe à l'intérieur du coffre en faisant glisser les supports entre la guide des châssis. Visser les supports aux châssis.
- GB** Step 1. Place the nuts on the end caps. Insert the axis into the box by sliding the supports between the end caps guide. Tighten the supports to the end caps with screws.
- I** Fase 1. Posizionare i dadi sulle testate. Inserire l'asse all'interno del cassonetto facendo scorrere i supporti tra la guida delle testate. Avvitare i supporti alle testate.

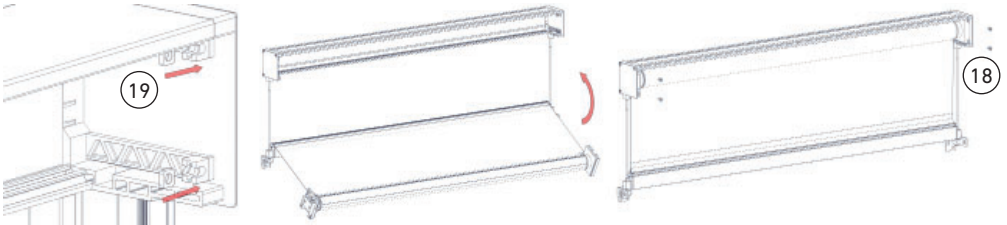



## 11.e Montaje perfil registro • Upper profile assembly Montage profil registre • Montaggio del profilo superiore

- E** Paso 1. Introducir el perfil registro en el cajón y atornillar.
- F** 1. Placer le profil registre sur le coffre et visser.
- GB** Step 1. Place the upper profile on the box and tighten the screws.
- I** Fase 1. Collocare il profilo superiore nel cassonetto e avvitare.

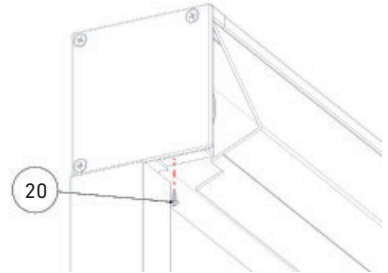
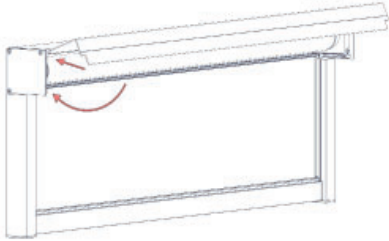







## **GAVIOTA**

Autovía de Alicante, A-31 Km.196  
03630 Sax (Alicante) - España / Spain  
Tel. +34 965 474 200•Fax +34 965 475 680  
International Dept: +34 966 968 276•Fax +34 966 968 075  
comercial@gaviotasimbac.com - export@gaviotasimbac.com  
www.gaviotasimbac.com